

***Memorex***<sup>®</sup>

**MT1196A**

# **SERVICE MANUAL**

**COLOR TELEVISION RECEIVER**

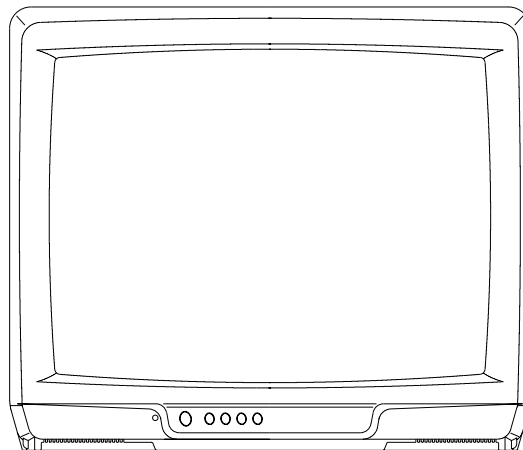

**ORIGINAL  
MFR'S VERSION D**

## SERVICING NOTICES ON CHECKING

### 1. KEEP THE NOTICES

As for the places which need special attentions, they are indicated with the labels or seals on the cabinet, chassis and parts. Make sure to keep the indications and notices in the operation manual.

### 2. AVOID AN ELECTRIC SHOCK

There is a high voltage part inside. Avoid an electric shock while the electric current is flowing.

### 3. USE THE DESIGNATED PARTS

The parts in this equipment have the specific characters of incombustibility and withstand voltage for safety. Therefore, the part which is replaced should be used the part which has the same character.

Especially as to the important parts for safety which is indicated in the circuit diagram or the table of parts as a  mark, the designated parts must be used.

### 4. PUT PARTS AND WIRES IN THE ORIGINAL POSITION AFTER ASSEMBLING OR WIRING

There are parts which use the insulation material such as a tube or tape for safety, or which are assembled in the condition that these do not contact with the printed board. The inside wiring is designed not to get closer to the pyrogenic parts and high voltage parts. Therefore, put these parts in the original positions.

### 5. TAKE CARE TO DEAL WITH THE CATHODE-RAY TUBE

In the condition that an explosion-proof cathode-ray tube is set in this equipment, safety is secured against implosion. However, when removing it or serving from backward, it is dangerous to give a shock. Take enough care to deal with it.

### 6. AVOID AN X-RAY

Safety is secured against an X-ray by considering about the cathode-ray tube and the high voltage peripheral circuit, etc.

Therefore, when repairing the high voltage peripheral circuit, use the designated parts and make sure not modify the circuit.

Repairing except indicates causes rising of high voltage, and it emits an X-ray from the cathode-ray tube.

### 7. PERFORM A SAFETY CHECK AFTER SERVICING

Confirm that the screws, parts and wiring which were removed in order to service are put in the original positions, or whether there are the portions which are deteriorated around the serviced places serviced or not. Check the insulation between the antenna terminal or external metal and the AC cord plug blades. And be sure the safety of that.

#### (INSULATION CHECK PROCEDURE)

1. Unplug the plug from the AC outlet.
2. Remove the antenna terminal on TV and turn on the TV.
3. Insulation resistance between the cord plug terminals and the external exposure metal **[Note 2]** should be more than 1M ohm by using the 500V insulation resistance meter **[Note1]** .
4. If the insulation resistance is less than 1M ohm, the inspection repair should be required.

#### **[Note 1]**

If you have not the 500V insulation resistance meter, use a Tester.

#### **[Note 2]**

External exposure metal: Antenna terminal

## HOW TO ORDER PARTS

Please include the following informations when you order parts. (Particularly the VERSION LETTER.)

#### 1. MODEL NUMBER and VERSION LETTER

The MODEL NUMBER can be found on the back of each product and the VERSION LETTER can be found at the end of the SERIAL NUMBER.

#### 2. PART NO. and DESCRIPTION

You can find it in your SERVICE MANUAL.

## IMPORTANT

Inferior silicon grease can damage IC's and transistors.

When replacing an IC's or transistors, use only specified silicon grease (YG6260M).

Remove all old silicon before applying new silicon.

# CONTENTS

<b>SERVICING NOTICES ON CHECKING</b> .....	A1-1
<b>HOW TO ORDER PARTS</b> .....	A1-1
<b>IMPORTANT</b> .....	A1-1
<b>CONTENTS</b> .....	A2-1
<b>GENERAL SPECIFICATIONS</b> .....	A3-1~A3-4
<b>DISASSEMBLY INSTRUCTIONS</b> .....	B-1
<b>SERVICE MODE LIST</b> .....	C-1
<b>CONFIRMATION OF USING HOURS</b> .....	C-1
<b>NOTE FOR THE REPLACING OF MEMORY IC</b> .....	C-1
<b>ELECTRICAL ADJUSTMENTS</b> .....	D1-1~D2-1
<b>MAJOR COMPONENTS LOCATION GUIDE</b> .....	D3-1
<b>BLOCK DIAGRAM</b> .....	E-1, E-2
<b>PRINTED CIRCUIT BOARDS</b>	
MAIN/CRT .....	F-1~F-4
<b>SCHEMATIC DIAGRAMS</b>	
MICON/TUNER .....	G-1, G-2
CHROMA .....	G-3, G-4
DEFLECTION/CRT .....	G-5, G-6
POWER .....	G-7, G-8
<b>WAVEFORMS</b> .....	H-1, H-2
<b>MECHANICAL EXPLODED VIEW</b> .....	I-1
<b>MECHANICAL REPLACEMENT PARTS LIST</b> .....	J1-1
<b>ELECTRICAL REPLACEMENT PARTS LIST</b> .....	J2-1, J2-2

# GENERAL SPECIFICATIONS

G-1.Outline of the Product

19 inch(480.0mmV):Measured diagonally  
Color CRT 90 degree deflection

G-2.Broadcasting System

US System M

G-3.Color System NTSC PAL SECAM or Monochrome signal

G-4.NTSC Playback(PAL 60Hz) Yes No

G-5.NTSC 3.58+4.43/PAL60Hz Yes No

G-6.Antenna Input Impedance

VHF/UHF 75 ohm unbalanced

G-7.Tuner and Receiving Channel

Tuner : Contactless Electric Tuner

Oscar(W/O HYPER) Oscar(W/ HYPER) France CATV Others  
channel coverage

2 ~ 69 , 4A , A-5 ~ A-1 , A ~ I , J ~ W , W+1 ~ W+84

Tuning System

Frequency syn. Voltage syn. Others

G-8.Preset Channel

-- channels

G-9.Intermediate Frequency

Picture(fP)	<u>45.75</u> MHz	<u>      </u> MHz	<u>      </u> MHz
Sound (fS)	<u>41.25</u> MHz	<u>      </u> MHz	<u>      </u> MHz
fP-fS	<u>4.50</u> MHz	<u>      </u> MHz	<u>      </u> MHz

G-10.Stereo/Dual TV Sound

Yes(NICAM GERMAN USA JAPAN) No

G-11.Tuner Sound Muting

Yes No

G-12.Power Source

120 V AC 50Hz AC 60Hz

G-13.Power Consumption:

80 W at AC 120 V 60 Hz

-- W at DC --- V

Stand by: 6 W at AC 120 V 60 Hz

Per Year: -- kWh / Year

G-14.Dimensions(Approx.)

488 mm(W) 465 mm(D) 416 mm(H)

G-15.Weight(Approx.)

Net: 17.5 kg ( 38.6 lbs)

Gross: 20.0 kg ( 44.1 lbs)

G-16.Cabinet Material

Cabinet Front: PS 94HB DECABROM  
ABS 94V2 NON-DECA  
94V0

Back Panel: PS 94HB DECABROM  
ABS 94V2 NON-DECA  
94V0

G-17.Protector:

Power Fuse

G-18.Regulation

Safety

<input checked="" type="checkbox"/> UL	<input checked="" type="checkbox"/> CSA	<input type="checkbox"/> SAA	<input type="checkbox"/> SI	<input type="checkbox"/> CE	<input type="checkbox"/> SEV
<input type="checkbox"/> BS	<input type="checkbox"/> NF	<input type="checkbox"/> NEMKO	<input type="checkbox"/> FEMKO	<input type="checkbox"/> DEMKO	<input type="checkbox"/> IEC65
<input type="checkbox"/> SEMKO	<input type="checkbox"/> NZ	<input type="checkbox"/> HOMOLO	<input type="checkbox"/> SABS	<input type="checkbox"/> CNS	<input type="checkbox"/> SISIR
<input type="checkbox"/> NOM	<input type="checkbox"/> AS3159	<input type="checkbox"/> DENTORI	<input type="checkbox"/> UNE	<input type="checkbox"/> GOST	<input type="checkbox"/> NONE

Radiation

<input checked="" type="checkbox"/> FCC	<input checked="" type="checkbox"/> DOC	<input type="checkbox"/> FTZ	<input type="checkbox"/> PTT	<input type="checkbox"/> CE	<input type="checkbox"/> SEV
<input type="checkbox"/> SABA	<input type="checkbox"/> SI	<input type="checkbox"/> NF	<input type="checkbox"/> NZ	<input type="checkbox"/> HOMOLO	<input type="checkbox"/> UNE
<input type="checkbox"/> CNS	<input type="checkbox"/> CISPR13	<input type="checkbox"/> DENTORI	<input type="checkbox"/> AS/NZS	<input type="checkbox"/> NONE	

X-Radiation

PTB DHHS HWC DENTORI NONE

## GENERAL SPECIFICATIONS

**G-19. Temperature**

Operation        5   °C ~  40  °C  
 Storage         -20  °C ~  60  °C

**G-20. Operating Humidity**

Less than  80  %RH

**G-21. Clock and Timer**

Sleep Timer             Yes Max  120  Min.(  10  Min. Step)             No  
 On/Off Timer          Yes \_\_\_\_\_ Programs                             No  
 Wake Up Timer         Yes \_\_\_\_\_ Programs                                 No

**G-22. Timer back up Time:**

More than   --   Minutes (at Power Off Mode)

**G-23. Terminals**

VHF/UHF Antenna Input                             Din Type       F-Type       France Type  
 Front Video Input      (RCA ø8.3)  
 Front Audio Input        (RCA ø8.3)  
 Rear Video Input         (RCA ø8.3)  
 Rear Audio Input         (RCA ø8.3)  
 Rear Video Output       (RCA ø8.3)  
 Rear Audio Output       (RCA ø8.3)  
 21 Pin     S Input(Rear)     Ear Phone Jack(ø3.5)

**G-24. Indicator**

Power                             Stand By                             On Timer                             NONE  
 (\_\_\_\_)                            (\_\_\_\_)                            (\_\_\_\_)

**G-25. Display**

**On Screen Display**

<input checked="" type="checkbox"/> Menu	<input type="checkbox"/> Clock Set( <input type="checkbox"/> 12H <input type="checkbox"/> 24H)	<input type="checkbox"/> System Selec	<input type="checkbox"/> On/Off Timer
<input type="checkbox"/> Hotel Lock	<input type="checkbox"/> Sound 1/2	<input type="checkbox"/> Area Code	<input checked="" type="checkbox"/> CH Tuning
<input type="checkbox"/> Guide CH Set	<input type="checkbox"/> CATV	<input type="checkbox"/> NICAM Auto Off	<input checked="" type="checkbox"/> Picture
<input checked="" type="checkbox"/> Control Level	<input checked="" type="checkbox"/> Sound	<input type="checkbox"/> Audio	<input checked="" type="checkbox"/> Language
<input checked="" type="checkbox"/> Color	<input checked="" type="checkbox"/> Tuning	<input type="checkbox"/> Pin Code Registration	<input checked="" type="checkbox"/> V-Chip
<input type="checkbox"/> Balance	<input checked="" type="checkbox"/> Brightness	<input checked="" type="checkbox"/> Tint(NTSC Only)	<input checked="" type="checkbox"/> Contrast
<input type="checkbox"/> Stereo, Audio Output, Bilingual	<input type="checkbox"/> Bass	<input type="checkbox"/> Back Light	<input type="checkbox"/> Sharpness
<input type="checkbox"/> Stereo, Audio Output, SAP	<input type="checkbox"/> Picture Menu	<input type="checkbox"/> Mid Night Theater	<input type="checkbox"/> Treble
<input type="checkbox"/> Stereo, Audio Output	<input type="checkbox"/> GAME	<input type="checkbox"/> Clock	<input type="checkbox"/> Hotel Lock
<input type="checkbox"/> AV	<input checked="" type="checkbox"/> Channel	<input type="checkbox"/> Pin Code	
<input checked="" type="checkbox"/> Sleep Timer	<input checked="" type="checkbox"/> Sound Mute		

**G-26. OSD Language**

Eng       Ger       Fre       Spa       Ita       Por       Jpn

**OSD Language Setting**

Eng       Ger       Fre       Spa       Ita       Por       Jpn  
 Not Applicable

**G-27. Speaker : Position**

Front       Side       Bottom

Size                              3   inches  
 Imp                              8   ohm x   1   pcs  
 Power                        Max  1.5  W  
                                   10%  1.0  W (Typical)

**G-28. EXT Speaker**

Yes        --   W                            Imp   --   ohm

## GENERAL SPECIFICATIONS

### G-29. Carton

Master Carton:  Need  No Need  
 Content: \_\_\_\_\_ Set  
 Material: \_\_\_\_\_ / \_\_\_\_\_ Corrugated Carton  
 Dimensions: \_\_\_\_\_ mm(L) \_\_\_\_\_ mm(W) \_\_\_\_\_ mm(D)  
 Description of Origin  Yes  No

### Gift Box

Material  Double/Brown Corrugated Carton ( with Photo Label)  
 Double/White Corrugated Carton ( with Photo Label)  
 Double Full Color Carton W/Photo  
 Dimensions: 546 mm(L) 526 mm(W) 472 mm(D)  
 Design: As Per Buyer's  
 Description of Origin:  Yes  No  
 Drop Test Natural Dropping At 1 Corner / 3 Edges / 6 Surfaces  
 Height  25cm  31cm  46cm  62cm  80cm  
 Container Stuffing: 436 Sets / 40' container

### G-30. Accessories

Owner's Manual ( W/Guarantee Card) [English/French]  
 AC Plug Adapter  Channel film  
 Battery (UM- 4 x 2 )  Remote Control Unit  
 Safety Tip  Toll Free Insert Sheet  
 Guarantee Card  Audio-Video Cord (RCA)  
 Registration Card  Warning Sheet  
 Quick Set-Up Sheet  Schematic Diagram  
 Information Sheet  U/V Mixer  
 75 ohm Coaxial Cable ( Single Shield  Double Shield)  
 300 ohm to 75 ohm VHF Antenna Adaptor  
 21pin Cable  Car Cord  
 Rod Antenna  
 Loop Antenna  One Pole  Two Pole ( F-Type  Din Type  France Type)  
 ( F-Type  Din Type  France Type)

### G-31. Other Features

Auto Degauss  Auto Search  Full OSD  
 Auto Shut Off  CH Allocation  Premiere  
 Canal+  SAP  Comb Filter  
 CATV(181CH)  Channel Lock  Auto CH Memory  
 Anti-Theft  Just Clock Function  Hotel Lock  
 Rental  Game Position  Fastext  
 Unitext  TopText  Closed Caption  
 Picture Menu  Mid Night Theater  V-Chip

### G-32. Switch

#### Front

Power(Tact)  Channel Up/Reset  Volume Up/Set Up  
 System Select  Channel Down/Enter  Volume Down/Set Down  
 Main Power SW  Sub Power  Menu:Vol Up + Vol Down

#### Rear

AC/DC  TV/CATV Selector  
 Degauss  Main Power SW

### G-33. Magnetic Field

BV : +0.45G  BV : +0.35G  BV : +0.25G  
 BH : 0.18G BH : 0.30G BH : 0.30G  
 BV : -0.15G  BV : -0.25G  BV : -0.50G  
 BH : 0.15G BH : 0.15G BH : 0.30G

## GENERAL SPECIFICATIONS

G-34.Remote Control Unit:

RC-74

Glow in Dark Remocon

Yes

No

Power Source:

D.C 3 V

Battery UM - 4 x 2

Total 26 Key

- |   |  |   |
|---|--|---|
| <input checked="" type="checkbox"/> Power           | <input checked="" type="checkbox"/> Quick View | <input type="checkbox"/> TV/AV                  |
| <input type="checkbox"/> Stand By                   | <input type="checkbox"/> Status                | <input type="checkbox"/> Bar Select             |
| <input checked="" type="checkbox"/> 0               | <input type="checkbox"/> Time Select           | <input type="checkbox"/> PAL/SECAM              |
| <input checked="" type="checkbox"/> 1               | <input type="checkbox"/> Time Set              | <input checked="" type="checkbox"/> Volume Up   |
| <input checked="" type="checkbox"/> 2               | <input checked="" type="checkbox"/> Mute       | <input checked="" type="checkbox"/> Volume Down |
| <input checked="" type="checkbox"/> 3               | <input type="checkbox"/> CH Skip               | <input type="checkbox"/> CH Call                |
| <input checked="" type="checkbox"/> 4               | <input checked="" type="checkbox"/> CH1/CH2    | <input checked="" type="checkbox"/> CH Down     |
| <input checked="" type="checkbox"/> 5               | <input type="checkbox"/> Channel               | <input checked="" type="checkbox"/> CH Up       |
| <input checked="" type="checkbox"/> 6               | <input type="checkbox"/> Text/Mix/TV           | <input type="checkbox"/> CH Down/Page Down      |
| <input checked="" type="checkbox"/> 7               | <input type="checkbox"/> Display Cancel        | <input type="checkbox"/> CH Up/Page Up          |
| <input checked="" type="checkbox"/> 8               | <input type="checkbox"/> Initial               | <input type="checkbox"/> Page +/-               |
| <input checked="" type="checkbox"/> 9               | <input type="checkbox"/> Store                 | <input type="checkbox"/> Program                |
| <input type="checkbox"/> 10                         | <input type="checkbox"/> Reveal                | <input type="checkbox"/> F/T/B                  |
| <input type="checkbox"/> 11                         | <input checked="" type="checkbox"/> Sleep      | <input type="checkbox"/> Hold                   |
| <input type="checkbox"/> 12                         | <input type="checkbox"/> Aft/Skip              | <input type="checkbox"/> List                   |
| <input type="checkbox"/> 1 *                        | <input type="checkbox"/> Preset                | <input type="checkbox"/> Rotate                 |
| <input type="checkbox"/> 2 *                        | <input type="checkbox"/> 5.5/6.5MHz            | <input type="checkbox"/> Browse                 |
| <input type="checkbox"/> 0/10                       | <input type="checkbox"/> Auto Memory           | <input type="checkbox"/> Std/Auto               |
| <input type="checkbox"/> Tone 1/2                   | <input type="checkbox"/> Auto                  | <input type="checkbox"/> Memory                 |
| <input type="checkbox"/> Info                       | <input checked="" type="checkbox"/> Call       | <input type="checkbox"/> Band Select            |
| <input type="checkbox"/> Mono/Auto                  | <input checked="" type="checkbox"/> Reset      | <input type="checkbox"/> Search                 |
| <input checked="" type="checkbox"/> TV/Caption/Text | <input checked="" type="checkbox"/> Menu       | <input type="checkbox"/> Clock/Program          |
| <input type="checkbox"/> Expand                     | <input checked="" type="checkbox"/> Enter      | <input type="checkbox"/> Clock/Set              |
| <input type="checkbox"/> Red                        | <input type="checkbox"/> Add                   | <input type="checkbox"/> Ch Set                 |
| <input type="checkbox"/> Cyan                       | <input type="checkbox"/> Delete                | <input checked="" type="checkbox"/> Set +       |
| <input type="checkbox"/> Normal                     | <input type="checkbox"/> Yellow                | <input checked="" type="checkbox"/> Set -       |
| <input type="checkbox"/> Color System               | <input type="checkbox"/> Random                | <input type="checkbox"/> Green                  |
| <input type="checkbox"/> Wide Seley                 | <input type="checkbox"/> Tuning Up/Time Text   | <input type="checkbox"/> Nicam/Mono             |
| <input type="checkbox"/> Auto Wide On/Off           | <input type="checkbox"/> Tuning Down/Reset     | <input type="checkbox"/> Tone A/B               |
| <input type="checkbox"/> Picture Position           | <input type="checkbox"/> Navi                  | <input type="checkbox"/> FM Transmitter         |
| <input type="checkbox"/> Direct Change/Auto Search  |  | <input type="checkbox"/> Back Light             |
| <input type="checkbox"/> Picture Menu               | <input type="checkbox"/> Mid Night Theater     |   |

# DISASSEMBLY INSTRUCTIONS

## 1. REMOVAL OF ANODE CAP

Read the following **NOTED** items before starting work.

- \* After turning the power off there might still be a potential voltage that is very dangerous. When removing the Anode Cap, make sure to discharge the Anode Cap's potential voltage.
- \* Do not use pliers to loosen or tighten the Anode Cap terminal, this may cause the spring to be damaged.

### REMOVAL

1. Follow the steps as follows to discharge the Anode Cap. (Refer to Fig. 1-1.)

Connect one end of an Alligator Clip to the metal part of a flat-blade screwdriver and the other end to ground. While holding the plastic part of the insulated screwdriver, touch the support of the Anode with the tip of the screwdriver.

A cracking noise will be heard as the voltage is discharged.

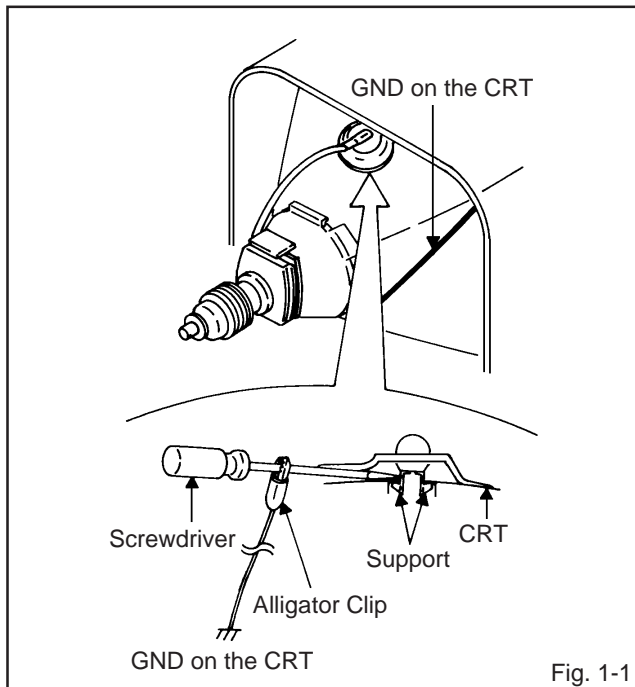

Fig. 1-1

2. Flip up the sides of the Rubber Cap in the direction of the arrow and remove one side of the support. (Refer to Fig. 1-2.)

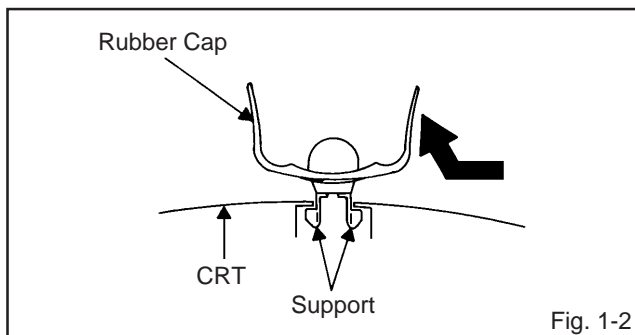

Fig. 1-2

3. After one side is removed, pull in the opposite direction to remove the other.

### NOTE

Take care not to damage the Rubber Cap.

### INSTALLATION

1. Clean the spot where the cap was located with a small amount of alcohol. (Refer to Fig. 1-3.)

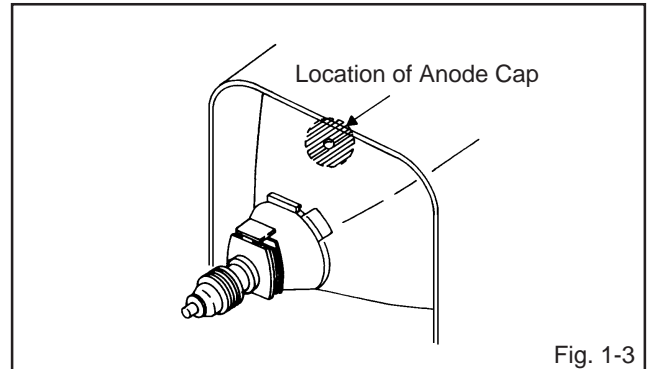

Fig. 1-3

### NOTE

Confirm that there is no dirt, dust, etc. at the spot where the cap was located.

2. Arrange the wire of the Anode Cap and make sure the wire is not twisted.
3. Turn over the Rubber Cap. (Refer to Fig. 1-4.)

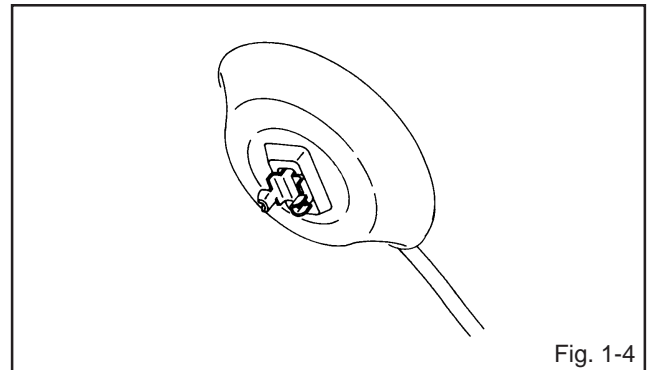

Fig. 1-4

4. Insert one end of the Anode Support into the anode button, then the other as shown in Fig. 1-5.

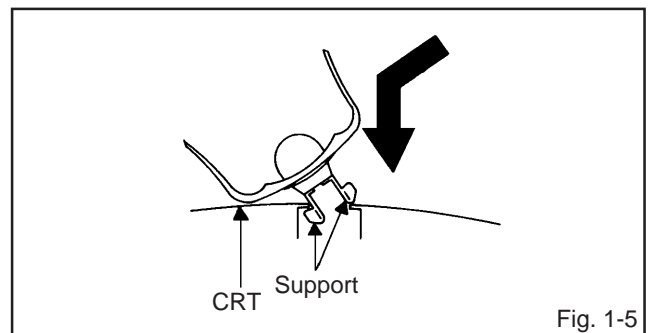

Fig. 1-5

5. Confirm that the Support is securely connected.
6. Put on the Rubber Cap without moving any parts.



## SERVICE MODE LIST

This unit provided with the following SERVICE MODES so you can repair, examine and adjust easily. To enter the Service Mode, press both set key and remote control key for more than 1 second.

Set Key	Remocon Key	Operations
VOL. (-) MIN	0	Releasing of V-CHIP PASSWORD.
VOL. (-) MIN	1	Initialization of the factory. NOTE: Do not use this for the normal servicing.
VOL. (-) MIN	6	POWER ON total hours is displayed on the screen. Refer to the "CONFIRMATION OF USING HOURS".  Can be checked of the INITIAL DATA of MEMORY IC. Refer to the "NOTE FOR THE REPLACING OF MEMORY IC".
VOL. (-) MIN	8	Writing of EEPROM initial data. NOTE: Do not use this for the normal servicing.
VOL. (-) MIN	9	Display of the Adjustment MENU on the screen. Refer to the "ELECTRICAL ADJUSTMENT" (On-Screen Display Adjustment).

### CONFIRMATION OF USING HOURS

POWER ON total hours can be checked on the screen. Total hours are displayed in 16 system of notation.

1. Set the VOLUME to minimum.
2. Press both VOL. DOWN button on the set and Channel button **(6)** on the remote control for more than 1 second.
3. After the confirmation of using hours, turn off the power.

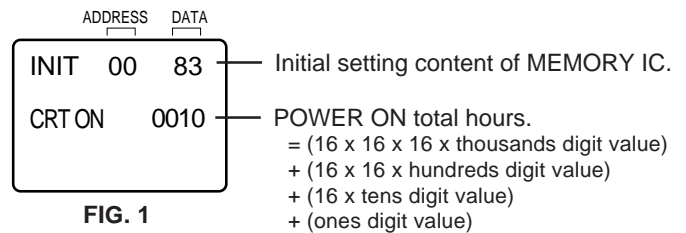

### NOTE FOR THE REPLACING OF MEMORY IC

If a service repair is undertaken where it has been required to change the MEMORY IC, the following steps should be taken to ensure correct data settings while making reference to TABLE 1.

ADDRESS	INI 00	INI 01	INI 02	INI 03	INI 04	INI 05	INI 06	INI 07	INI 08	INI 09	INI 0A
DATA	28	09	A0	01	02	B3	24	18	01	24	F4

**Table 1**

1. Enter DATA SET mode by setting VOLUME to minimum.
2. Press both VOL. DOWN button on the set and Channel button **(6)** on the remote control for more than 1 second. ADDRESS and DATA should appear as FIG 1.
3. ADDRESS is now selected and should "blink". Using the SET + or - keys on the remote, step through the ADDRESS until required ADDRESS to be changed is reached.
4. Press ENTER to select DATA. When DATA is selected, it will "blink".
5. Again, step through the DATA using SET + or - until required DATA value has been selected.
6. Pressing ENTER will take you back to ADDRESS for further selection if necessary.
7. Repeat steps 3 to 6 until all data has been checked.
8. When satisfied correct DATA has been entered, turn POWER off (return to STANDBY MODE) to finish DATA input. The unit will now have the correct DATA for the new MEMORY IC.

# ELECTRICAL ADJUSTMENTS

## 1. BEFORE MAKING ELECTRICAL ADJUSTMENTS

Read and perform these adjustments when repairing the circuits or replacing electrical parts or PCB assemblies.

### CAUTION

- Use an isolation transformer when performing any service on this chassis.
- Before removing the anode cap, discharge electricity because it contains high voltage.
- When removing a PCB or related component, after unfastening or changing a wire, be sure to put the wire back in its original position.  
Inferior silicon grease can damage IC's and transistors.
- When replacing IC's and transistors, use only specified silicon grease (YG6260M).  
Remove all old silicon before applying new silicon.

Prepare the following measurement tools for electrical adjustments.

1. Synchro Scope
2. Digital Voltmeter

### On-Screen Display Adjustment

1. In the condition of NO indication on the screen.  
Press the VOL. DOWN button on the set and the Channel button (9) on the remote control for more than 1 second to appear the adjustment mode on the screen as shown in Fig. 1-1.

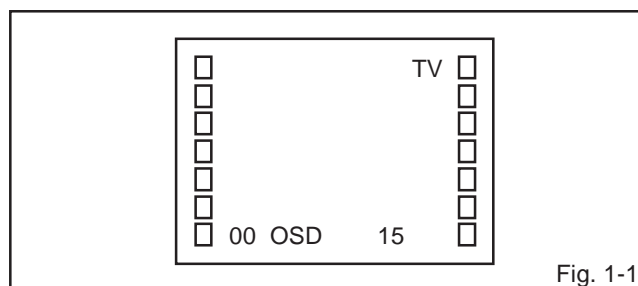

Fig. 1-1

2. Use the Channel UP/DOWN button or Channel button (0-9) on the remote control to select the options shown in Fig. 1-2.
3. Press the MENU button on the remote control to end the adjustments.

NO.	FUNCTION	NO.	FUNCTION
00	OSD H	13	BRIGHTNESS
01	CUT OFF	14	CONTRAST
02	RF AGC	15	COLOR
03	VIF VCO	16	TINT
04	H VCO	17	SHARPNESS
05	H PHASE	18	FM LEVEL
06	V SIZE	19	LEVEL
07	V SHIFT	20	SEPARATION 1
08	R DRIVE	21	SEPARATION 2
09	B DRIVE	22	TEST MONO
10	R BIAS	23	TEST STEREO
11	G BIAS	24	X-RAY TEST
12	B BIAS		

Fig. 1-2

## 2. BASIC ADJUSTMENTS

### 2-1: RF AGC DELAY

1. Receive an 80dB monoscope pattern.
2. Connect the digital voltmeter between the TP001 and the GND.
3. Activate the adjustment mode display of Fig. 1-1 and press the channel button (02) on the remote control to select "RF AGC".
4. Press the VOL. UP/DOWN button on the remote control until the digital voltmeter is  $1.95 \pm 0.05V$ .

### 2-2: CUT OFF

1. Adjust the unit to the following settings.  
R DRIVE=10, B DRIVE=10, R BIAS=64, G BIAS=64, B BIAS=64, BRIGHTNESS=126, CONTRAST=98
2. Place the set with Aging Test for more than 15 minutes.
3. Activate the adjustment mode display of Fig. 1-1 and press the channel button (01) on the remote control to select "CUT OFF".
4. Adjust the Screen Volume until a dim raster is obtained.

### 2-3: FOCUS

1. Receive the monoscope pattern.
2. Turn the Focus Volume fully counterclockwise once.
3. Adjust the Focus Volume until picture is distinct.

### 2-4: WHITE BALANCE

**NOTE:** Adjust after performing CUT OFF adjustments.

1. Place the set with Aging Test for more than 10 minutes.
2. Receive the color bar pattern.
3. Activate the adjustment mode display of Fig. 1-1 and press the channel button (10) on the remote control to select "R. BIAS".
4. Using the VOL. UP/DOWN button on the remote control, adjust "R. BIAS".
5. Press the CH UP/DOWN button on the remote control to select the "R. DRIVE", "B. DRIVE", "G. BIAS", or "B. BIAS".
6. Using the VOL. UP/DOWN button on the remote control, adjust the R. DRIVE, B. DRIVE, G. BIAS or B. BIAS.
7. Perform the above adjustments 5 and 6 until the white color is looked like a white.

### 2-5: SUB TINT/SUB COLOR

1. Receive the color bar pattern.
2. Connect the synchro scope to TP023.
3. Activate the adjustment mode display of Fig. 1-1 and press the channel button (16) on the remote control to select "TINT".
4. Press the VOL. UP/DOWN button on the remote control until the waveform becomes as shown in Fig. 2-1.
5. Connect the synchro scope to TP022.
6. Press the CH DOWN button once to set to "COLOR" mode.
7. Press the VOL. UP/DOWN button on the remote control until the red color level is adjusted to  $110 \pm 10\%$  of the white level. (Refer to Fig. 2-2)

## ELECTRICAL ADJUSTMENTS

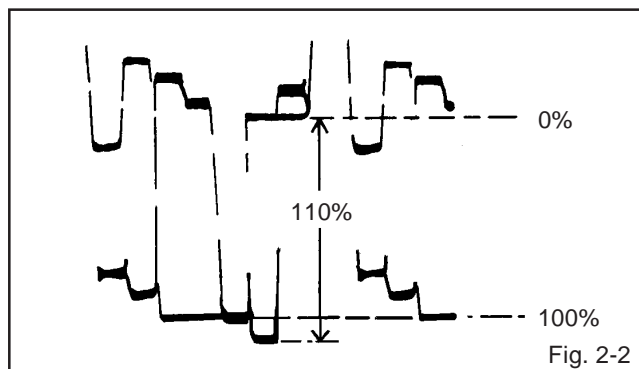
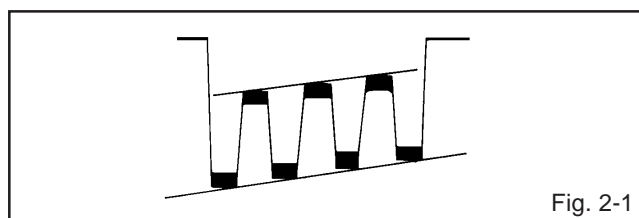

### 2-6: VERTICAL SHIFT

1. Receive the color bar pattern.
2. Activate the adjustment mode display of **Fig. 1-1** and press the channel button **(07)** on the remote control to select "V SHIFT".
3. Press the VOL. UP/DOWN button on the remote control until the horizontal line of the color bar comes to approximate center of the CRT.

### 2-7: VERTICAL SIZE

1. Receive the crosshatch pattern.
2. Activate the adjustment mode display of **Fig. 1-1** and press the channel button **(06)** on the remote control to select "V SIZE".
3. Press the VOL. UP/DOWN button on the remote control until the center of crosshatch is square.

### 2-8: HORIZONTAL PHASE

1. Receive the color bar pattern.
2. Activate the adjustment mode display of **Fig. 1-1** and press the channel button **(05)** on the remote control to select "H PHASE".
3. Press the VOL. UP/DOWN button on the remote control until the SHIFT quantity of the OVER SCAN on right and left becomes minimum.

### 2-9: OSD HORIZONTAL

1. Activate the adjustment mode display of **Fig. 1-1**.
2. Press the VOL. UP/DOWN button on the remote control until the difference of A and B becomes minimum. (Refer to **Fig. 2-3**)

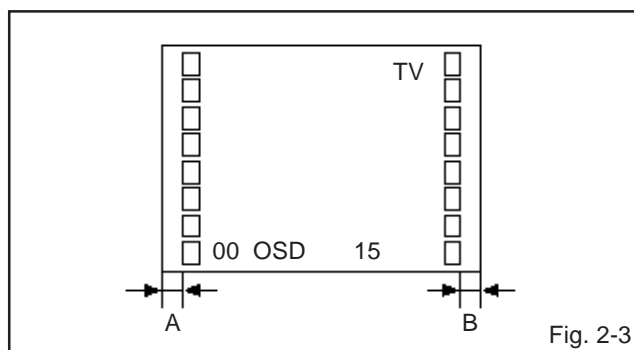

### 2-10: VERTICAL VCO

1. Place the set with Aging Test for more than 10 minutes.
2. Receive an 80dB monoscope pattern.
3. Connect the digital voltmeter between the **pin 5 of CP601** and the **GND**.
4. Activate the adjustment mode display of **Fig. 1-1** and press the channel button **(03)** on the remote control to select "VIF VCO".
5. Press the VOL. UP/DOWN button on the remote control until the digital voltmeter is 2.5V.

# ELECTRICAL ADJUSTMENTS

## 3. PURITY AND CONVERGENCE ADJUSTMENTS

### NOTE

1. Turn the unit on and let it warm up for at least 30 minutes before performing the following adjustments.
2. Place the CRT surface facing east or west to reduce the terrestrial magnetism.
3. Turn ON the unit and demagnetize with a Degauss Coil.

### 3-1: STATIC CONVERGENCE (ROUGH ADJUSTMENT)

1. Tighten the screw for the magnet. Refer to the adjusted CRT for the position. **(Refer to Fig. 3-1)**  
If the deflection yoke and magnet are in one body, untighten the screw for the body.
2. Receive the green raster pattern from the color bar generator.
3. Slide the deflection yoke until it touches the funnel side of the CRT.
4. Adjust center of screen to green, with red and blue on the sides, using the pair of purity magnets.
5. Switch the color bar generator from the green raster pattern to the crosshatch pattern.
6. Combine red and blue of the 3 color crosshatch pattern on the center of the screen by adjusting the pair of 4 pole magnets.
7. Combine red/blue (magenta) and green by adjusting the pair of 6 pole magnets.
8. Adjust the crosshatch pattern to change to white by repeating steps 6 and 7.

### 3-2: PURITY

#### NOTE

Adjust after performing adjustments in section 3-1.

1. Receive the green raster pattern from color bar generator.
2. Adjust the pair of purity magnets to center the color on the screen.  
Adjust the pair of purity magnets so the color at the ends are equally wide.
3. Move the deflection yoke backward (to neck side) slowly, and stop it at the position when the whole screen is green.
4. Confirm red and blue colors.
5. Adjust the slant of the deflection yoke while watching the screen, then tighten the fixing screw.

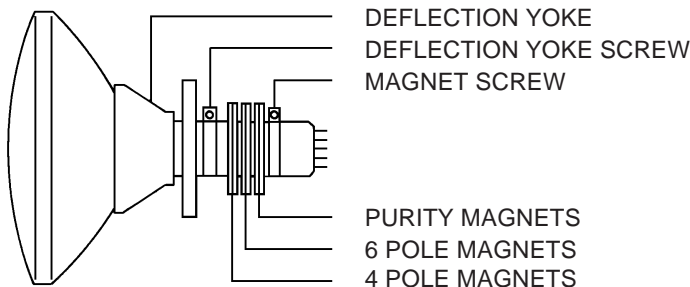

Fig. 3-1

### 3-3: STATIC CONVERGENCE

#### NOTE

Adjust after performing adjustments in section 3-2.

1. Receive the crosshatch pattern from the color bar generator.
2. Combine red and blue of the 3 color crosshatch pattern on the center of the screen by adjusting the pair of 4 pole magnets.
3. Combine red/blue (magenta) and green by adjusting the pair of 6 pole magnets.

### 3-4: DYNAMIC CONVERGENCE

#### NOTE

Adjust after performing adjustments in section 3-3.

1. Adjust the differences around the screen by moving the deflection yoke upward/downward and right/left. **(Refer to Fig. 3-2-a)**
2. Insert three wedges between the deflection yoke and CRT funnel to fix the deflection yoke. **(Refer to Fig. 3-2-b)**

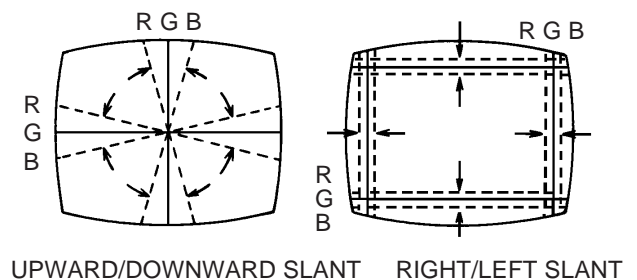

Fig. 3-2-a

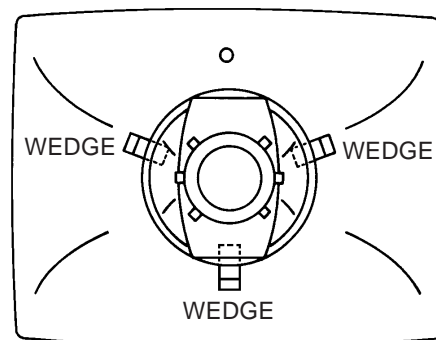
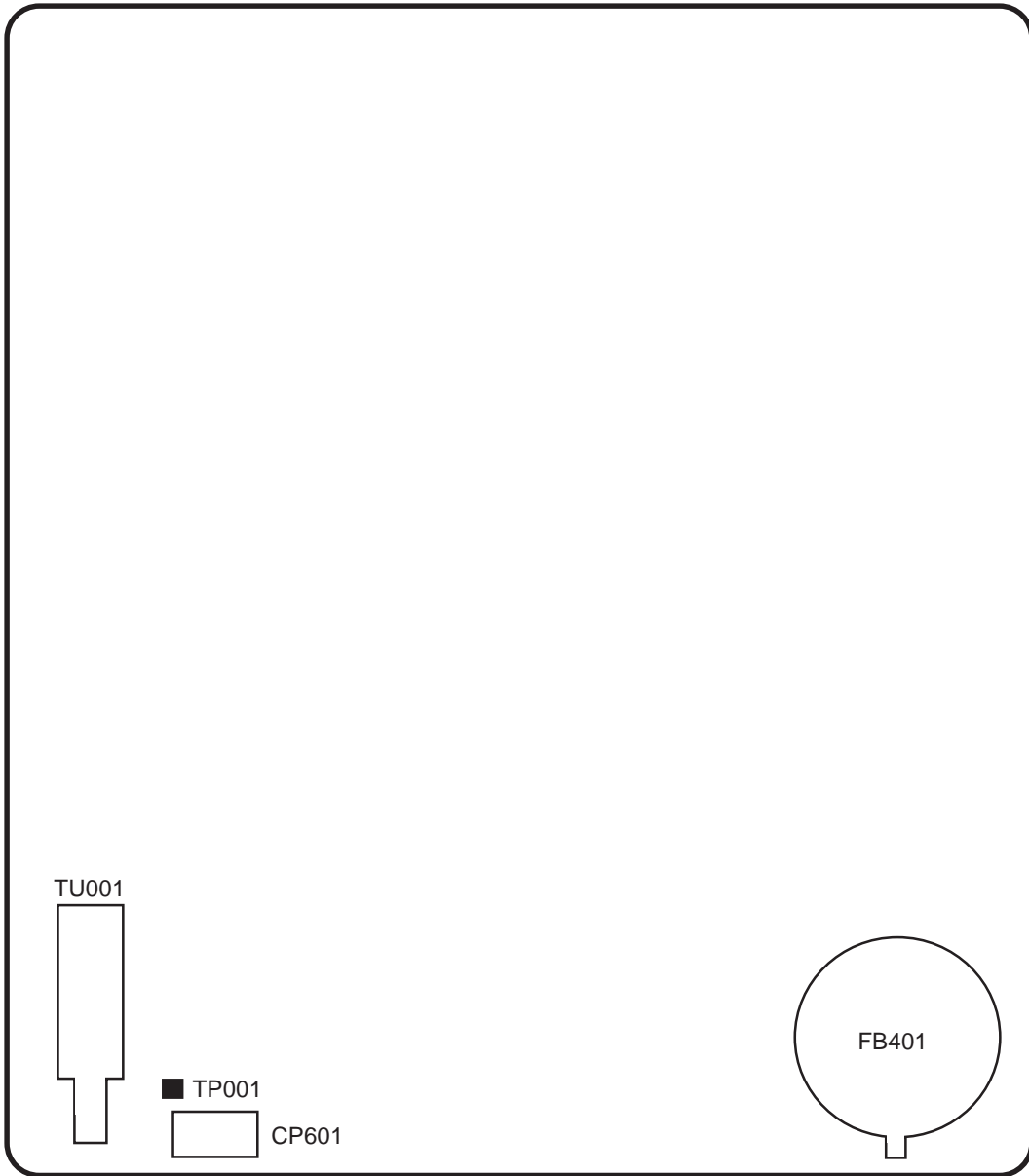

Fig. 3-2-b

# MAJOR COMPONENTS LOCATION GUIDE



FOCUS VOLUME  
SCREEN VOLUME

## MAIN

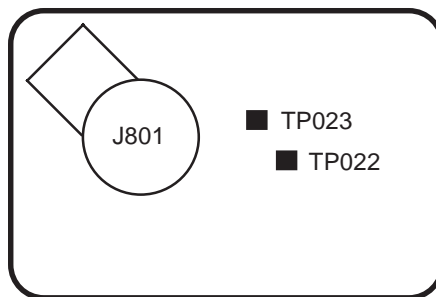

## CRT

# BLOCK DIAGRAM

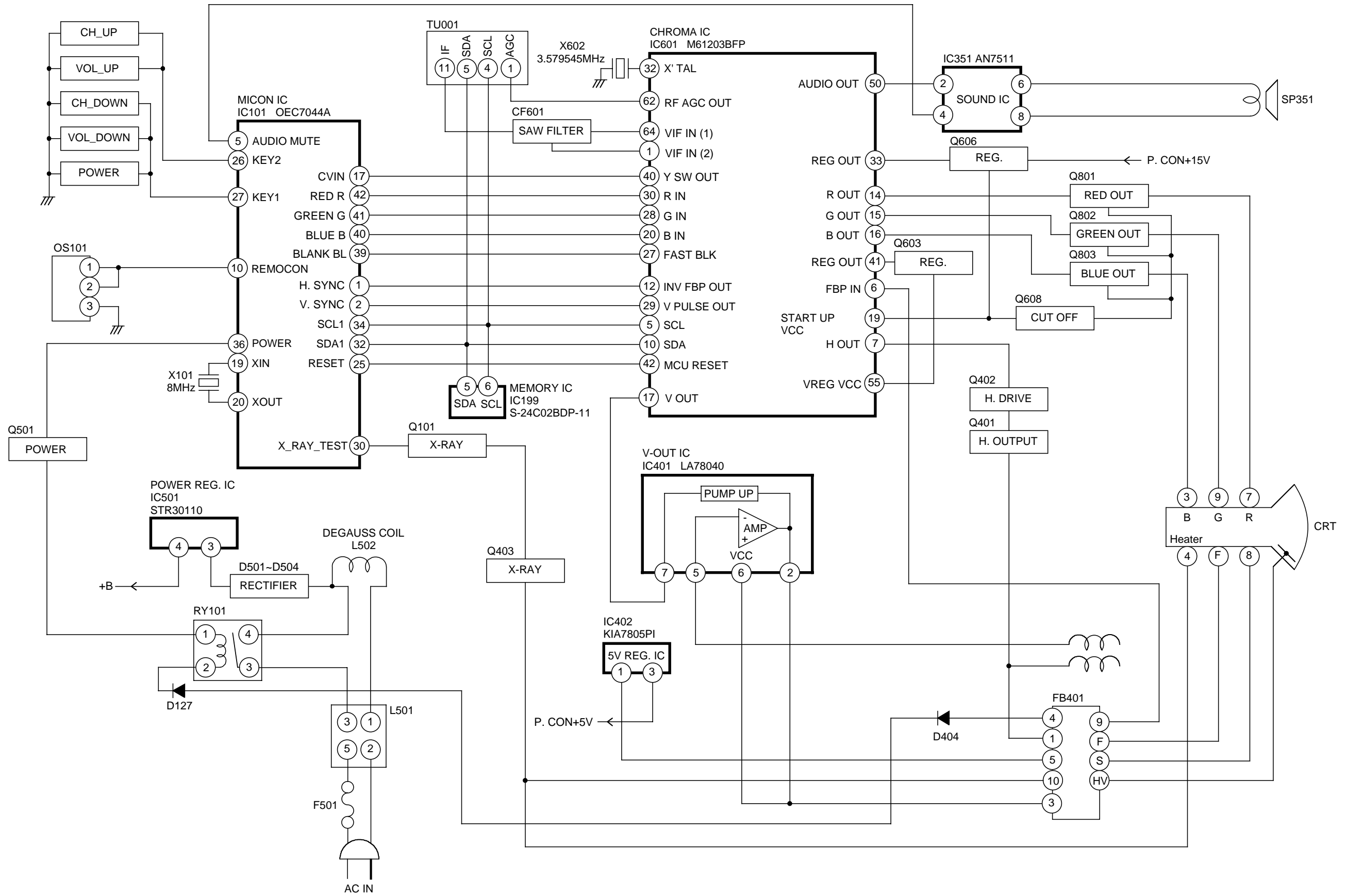

PRINTED CIRCUIT BOARDS  
MAIN/CRT (INSERTED PARTS)  
SOLDER SIDE

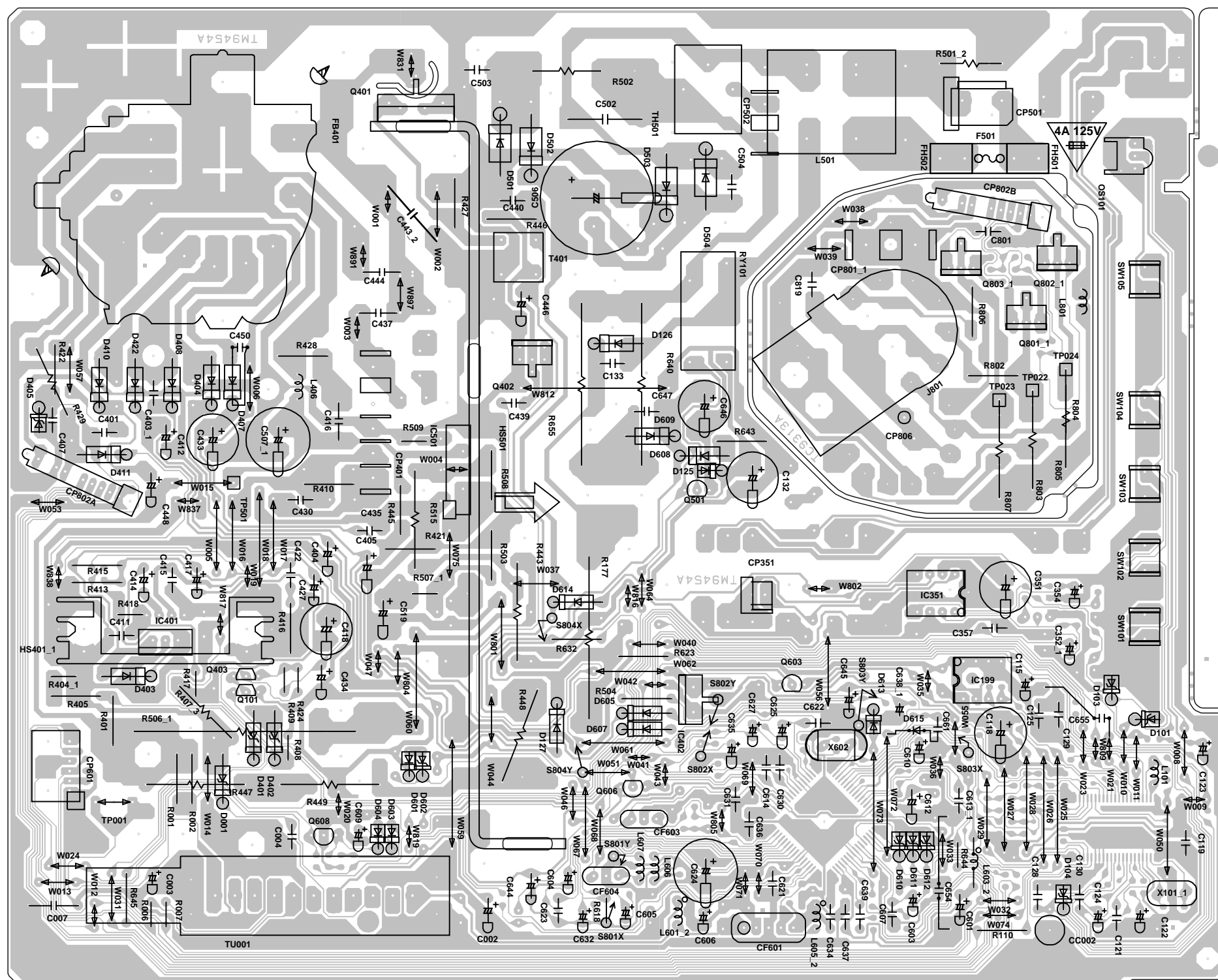

PRINTED CIRCUIT BOARDS  
MAIN/CRT (CHIP MOUNTED PARTS)  
SOLDER SIDE

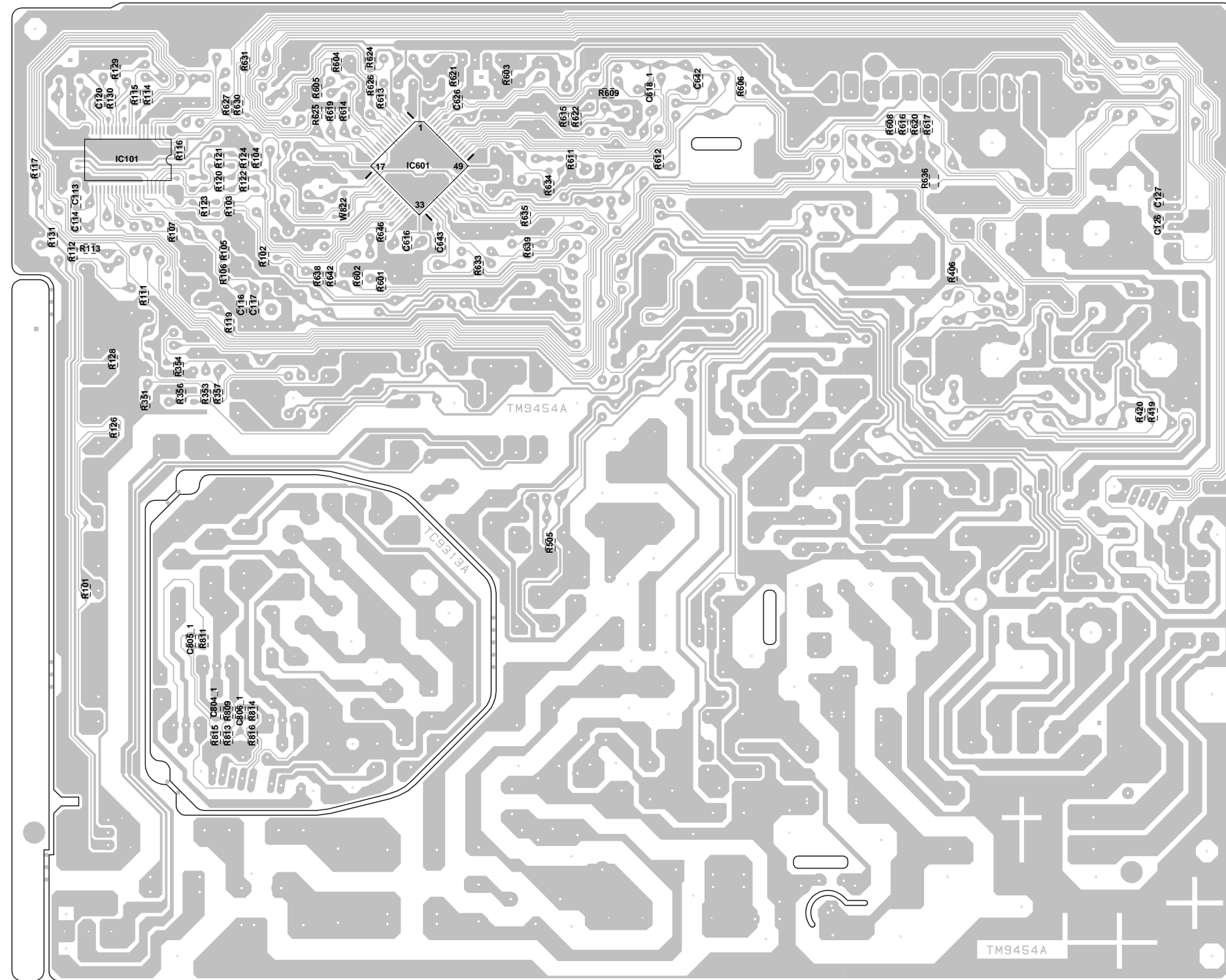



# MICON/TUNER SCHEMATIC DIAGRAM (MAIN PCB)

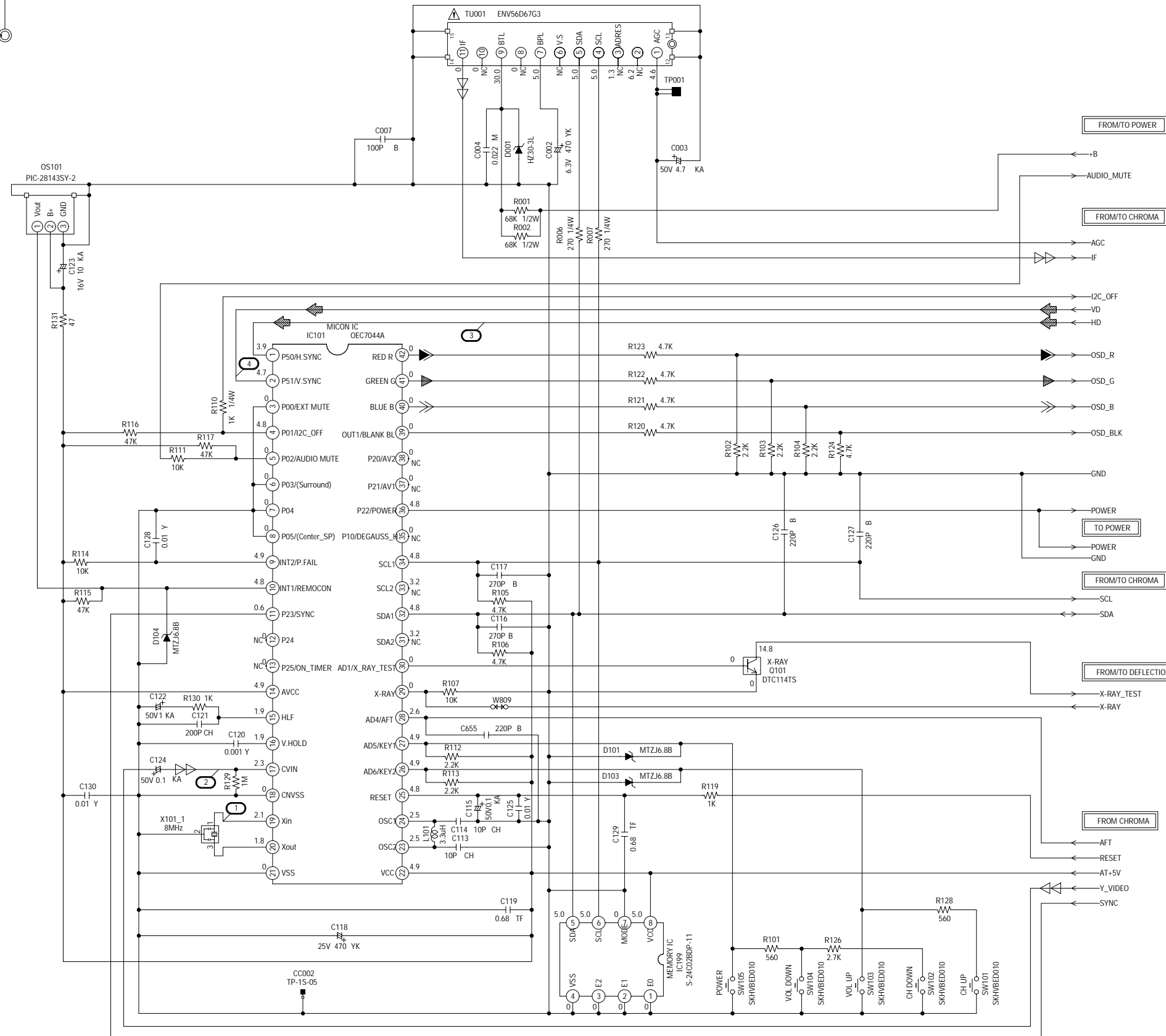
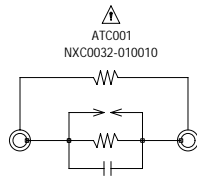
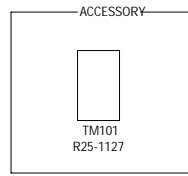

NOTE: THIS SCHEMATIC DIAGRAM IS THE LATEST AT THE TIME OF PRINTING AND SUBJECT TO CHANGE WITHOUT NOTICE.

NOTE: THE DC VOLTAGE AT EACH PART WAS MEASURED WITH THE DIGITAL TESTER WHEN THE COLOR BROADCAST WAS RECEIVED IN GOOD CONDITION AND PICTURE IS NORMAL.

CAUTION: SINCE THESE PARTS MARKED BY ARE CRITICAL FOR SAFETY, USE ONES DESCRIBED IN PARTS LIST ONLY.

ATTENTION: LES PIÈCES RÉPARÉES PAR UN ÉTANT DANGEREUSES AN POINT DE VUE SECURITE N'UTILISER QUE CELLES DECRITES DANS LA NOMENCLATURE DES PIÈCES.

CAUTION: DIGITAL TRANSISTOR

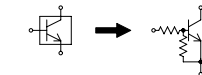

- DEFLECTION SIGNAL
- TUNER VIDEO SIGNAL
- R. SIGNAL
- G. SIGNAL
- B. SIGNAL

PCB010  
TM9454

# CHROMA SCHEMATIC DIAGRAM (MAIN PCB)

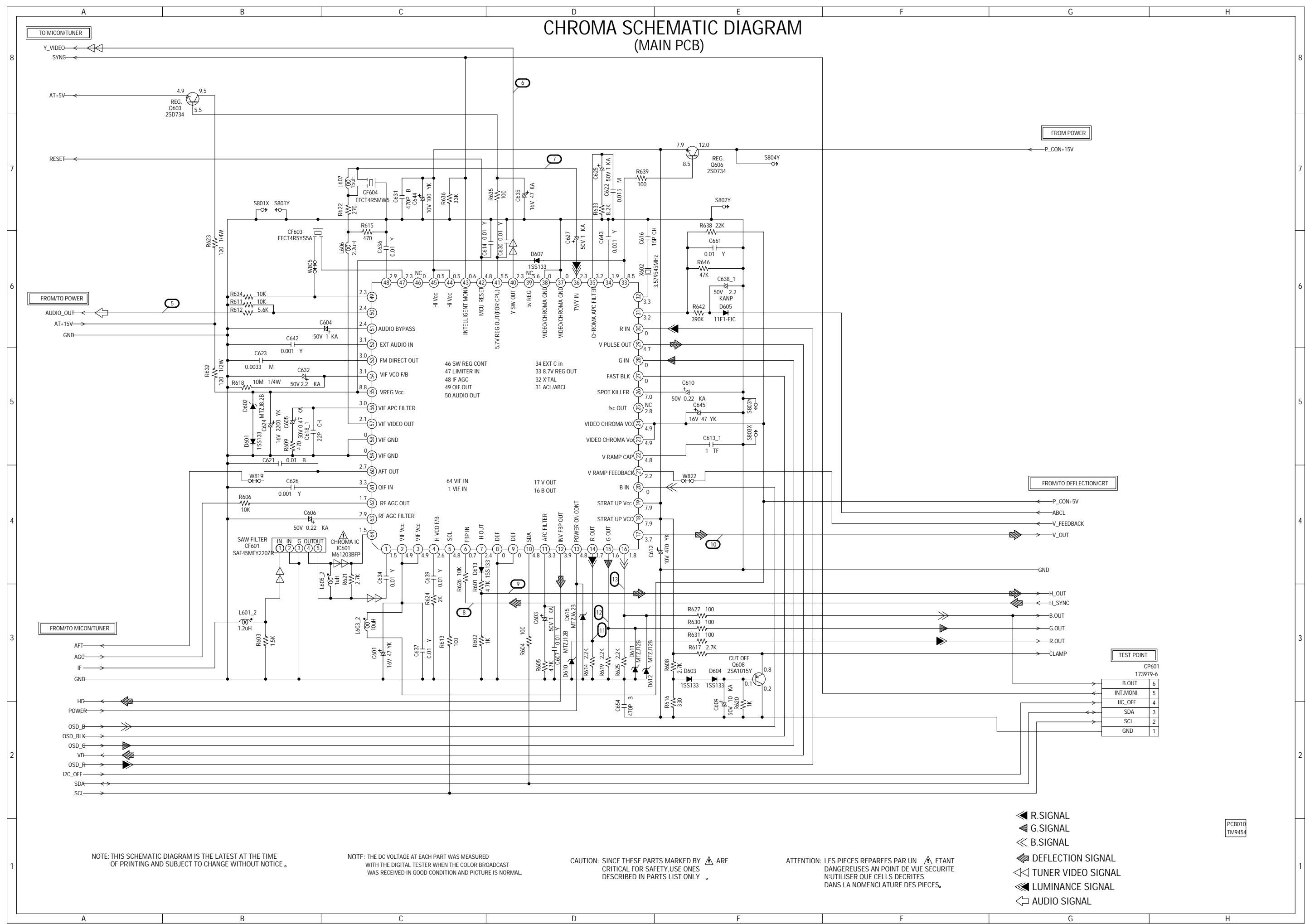

NOTE: THIS SCHEMATIC DIAGRAM IS THE LATEST AT THE TIME OF PRINTING AND SUBJECT TO CHANGE WITHOUT NOTICE.

NOTE: THE DC VOLTAGE AT EACH PART WAS MEASURED WITH THE DIGITAL TESTER WHEN THE COLOR BROADCAST WAS RECEIVED IN GOOD CONDITION AND PICTURE IS NORMAL.

CAUTION: SINCE THESE PARTS MARKED BY ARE CRITICAL FOR SAFETY USE ONES DESCRIBED IN PARTS LIST ONLY.

ATTENTION: LES PIECES REPARÉES PAR UN ÉTANT DANGEREUSES AN POINT DE VUE SECURITE N'UTILISER QUE CELLS DECRITES DANS LA NOMENCLATURE DES PIECES.

- R.SIGNAL
- G.SIGNAL
- B.SIGNAL
- DEFLECTION SIGNAL
- TUNER VIDEO SIGNAL
- LUMINANCE SIGNAL
- AUDIO SIGNAL

TEST POINT	
CP601	
173979-6	
B OUT	6
INT_MONI	5
IIC_OFF	4
SDA	3
SCL	2
GND	1

PCB010  
TM9454

# DEFLECTION/CRT SCHEMATIC DIAGRAM (MAIN PCB)

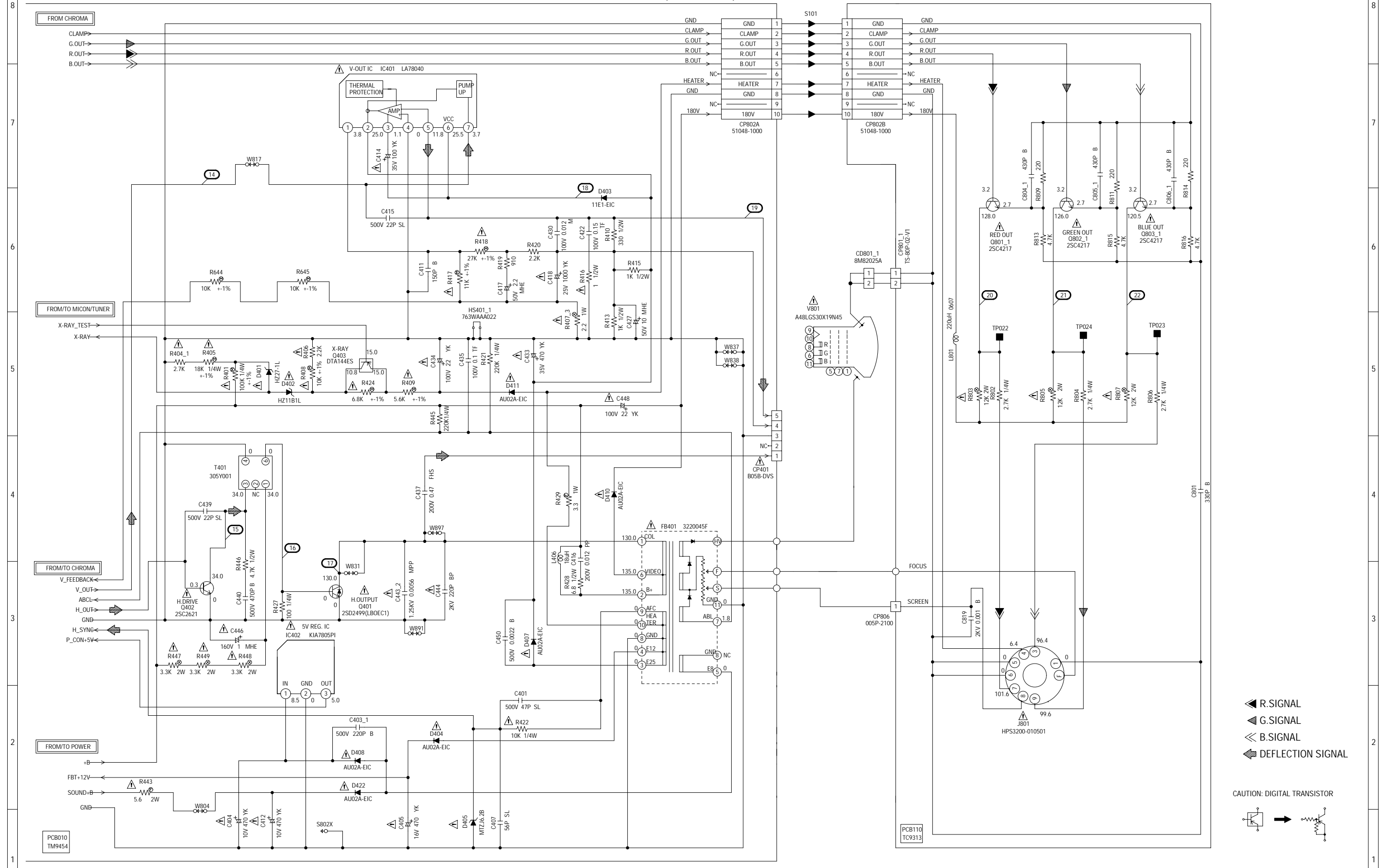

NOTE: THIS SCHEMATIC DIAGRAM IS THE LATEST AT THE TIME OF PRINTING AND SUBJECT TO CHANGE WITHOUT NOTICE.

NOTE: THE DC VOLTAGE AT EACH PART WAS MEASURED WITH THE DIGITAL TESTER WHEN THE COLOR BROADCAST WAS RECEIVED IN GOOD CONDITION AND PICTURE IS NORMAL.

CAUTION: SINCE THESE PARTS MARKED BY ARE CRITICAL FOR SAFETY, USE ONES DESCRIBED IN PARTS LIST ONLY.

ATTENTION: LES PIÈCES RÉPARÉES PAR UN ÉTANT DANGEREUSES AU POINT DE VUE SÉCURITÉ N'UTILISER QUE CELLES DÉCRITES DANS LA NOMENCLATURE DES PIÈCES.

- R.SIGNAL
- G.SIGNAL
- B.SIGNAL
- DEFLECTION SIGNAL

CAUTION: DIGITAL TRANSISTOR

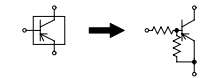

# POWER SCHEMATIC DIAGRAM (MAIN PCB)

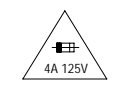

CAUTION: FOR CONTINUED PROTECTION AGAINST FIRE HAZARD, REPLACE ONLY WITH THE SAME TYPE 4A 125V (F501) FUSE.  
ATTENTION: POUR UNE PROTECTION CONTINUE LES RISQUES D'INCENDIE N'UTILISER QUE DES FUSIBLES DE MEME TYPE 4A 125V (F501).

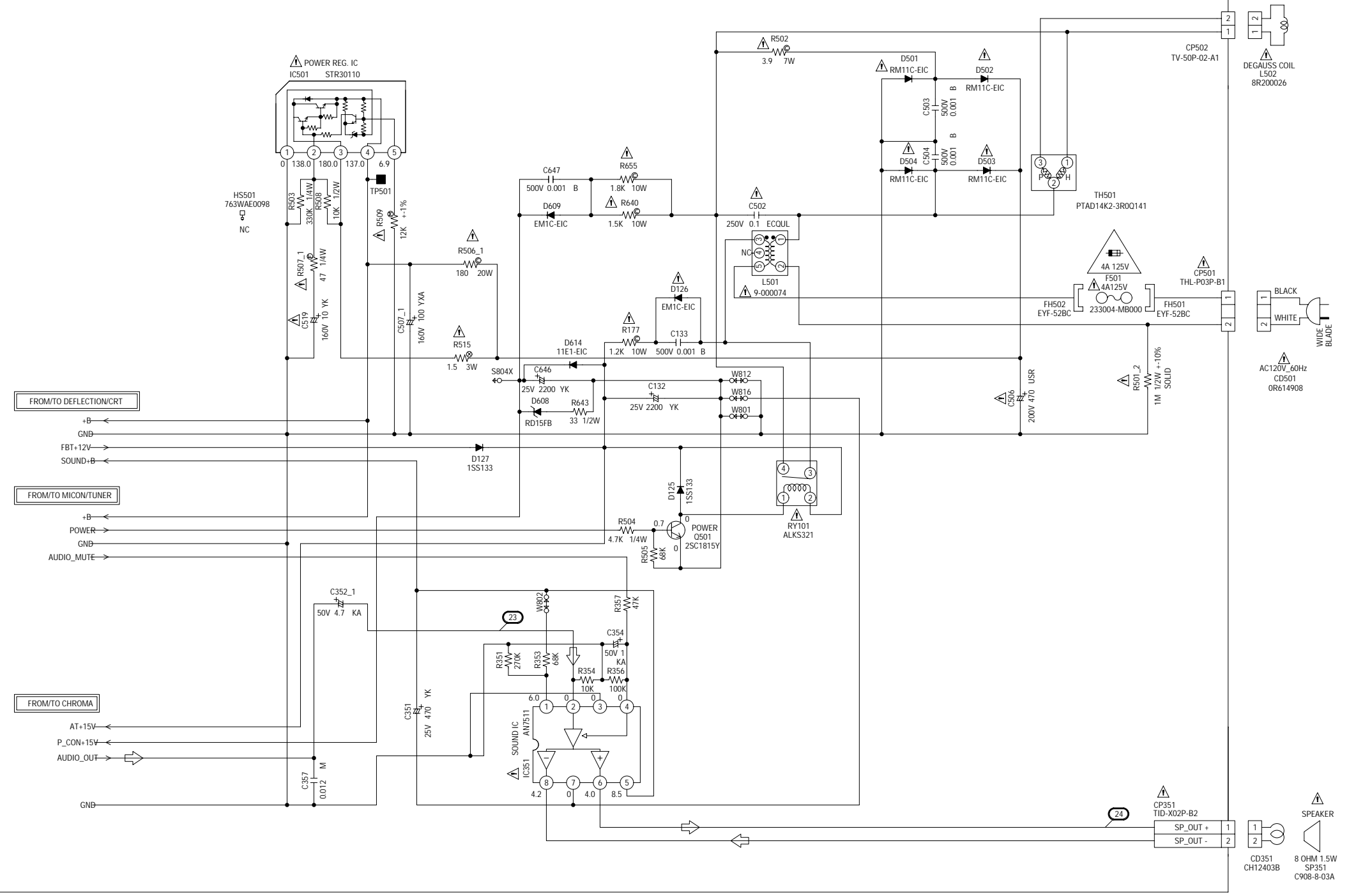

NOTE: THIS SCHEMATIC DIAGRAM IS THE LATEST AT THE TIME OF PRINTING AND SUBJECT TO CHANGE WITHOUT NOTICE.

NOTE: THE DC VOLTAGE AT EACH PART WAS MEASURED WITH THE DIGITAL TESTER WHEN THE COLOR BROADCAST WAS RECEIVED IN GOOD CONDITION AND PICTURE IS NORMAL.

CAUTION: SINCE THESE PARTS MARKED WITH THE TRIANGLE SYMBOL ARE CRITICAL FOR SAFETY, USE ONES DESCRIBED IN PARTS LIST ONLY.

ATTENTION: LES PIECES REPAREES PAR UN ETANT DANGEREUSES AN POINT DE VUE SECURITE N'UTILISER QUE CELLES DECRITES DANS LA NOMENCLATURE DES PIECES.

PCB010  
TM9454

AUDIO SIGNAL

# WAVEFORMS

## MICON/TUNER

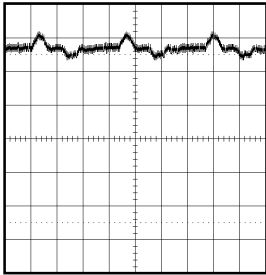

① 200mV 5ms/div

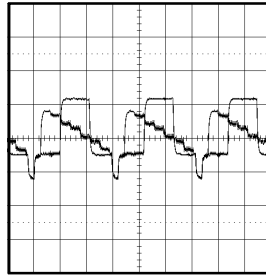

⑥ 0.5V 20μs/div

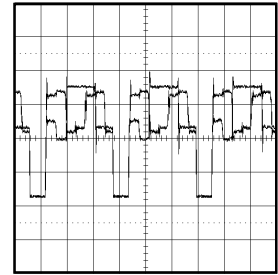

⑪ 1V 20μs/div

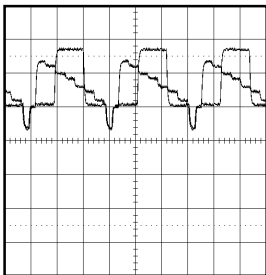

② 0.5V 20μs/div

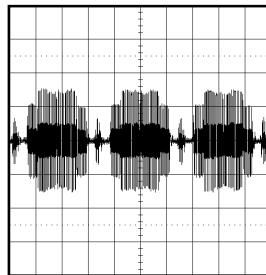

⑦ 200mV 20μs/div

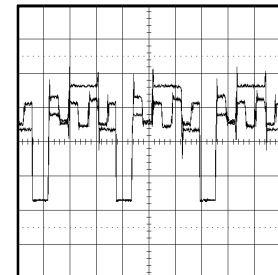

⑫ 1V 20μs/div

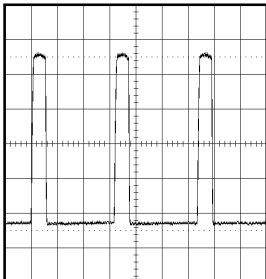

③ 200mV 20μs/div

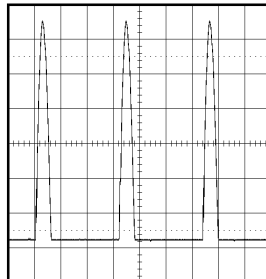

⑧ 20V 20μs/div

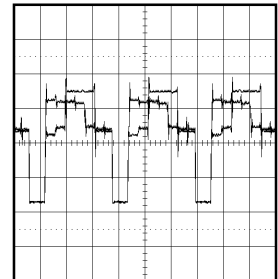

⑬ 1V 20μs/div

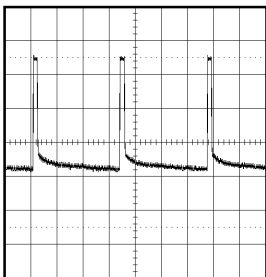

④ 200mV 5ms/div

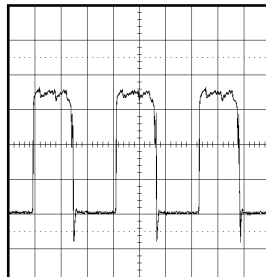

⑨ 200mV 20μs/div

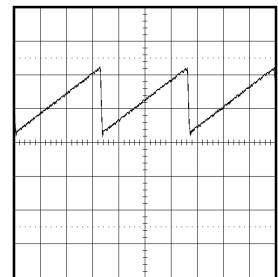

⑭ 0.5V 5ms/div

## CHROMA

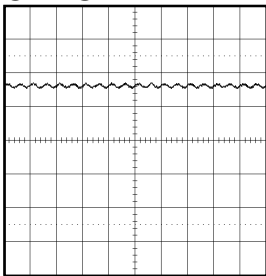

⑤ 0.5V 2ms/div

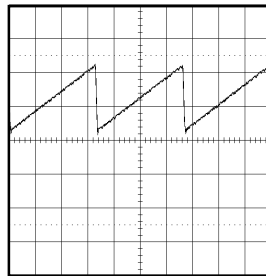

⑩ 0.5V 5ms/div

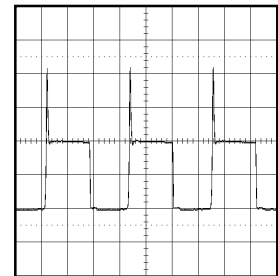

⑮ 20V 20μs/div

NOTE: The following waveforms were measured at the point of the corresponding balloon number in the schematic diagram.

## WAVEFORMS

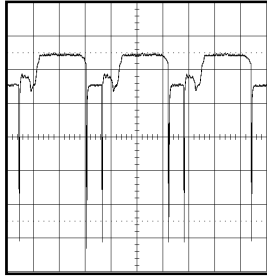

①⑥ 2V 20μs/div

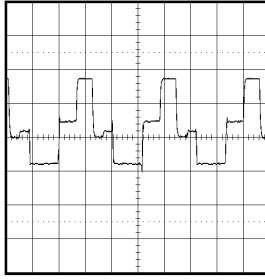

②① 50V 20μs/div

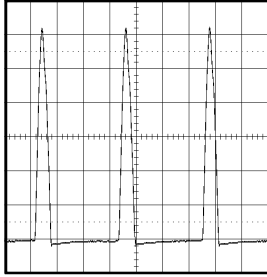

①⑦ 200V 20μs/div

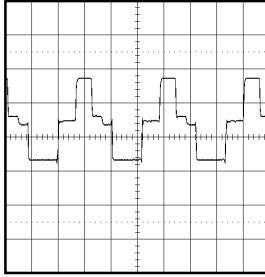

②② 50V 20μs/div

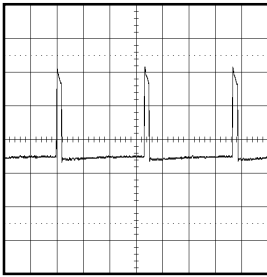

①⑧ 10V 5ms/div

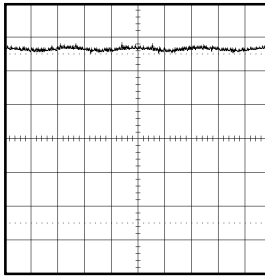

②③ 0.5V 1ms/div

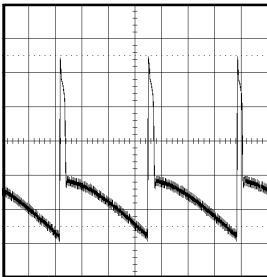

①⑨ 10V 5ms/div

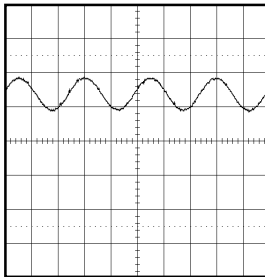

②④ 1V 1ms/div

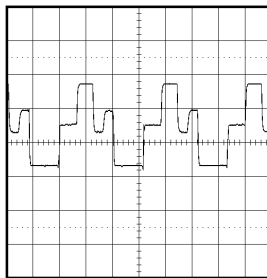

②⑤ 50V 20μs/div

## POWER

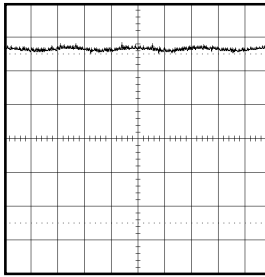

②③ 0.5V 1ms/div

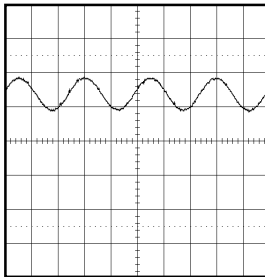

②④ 1V 1ms/div

NOTE: The following waveforms were measured at the point of the corresponding balloon number in the schematic diagram.

# MECHANICAL EXPLODED VIEW

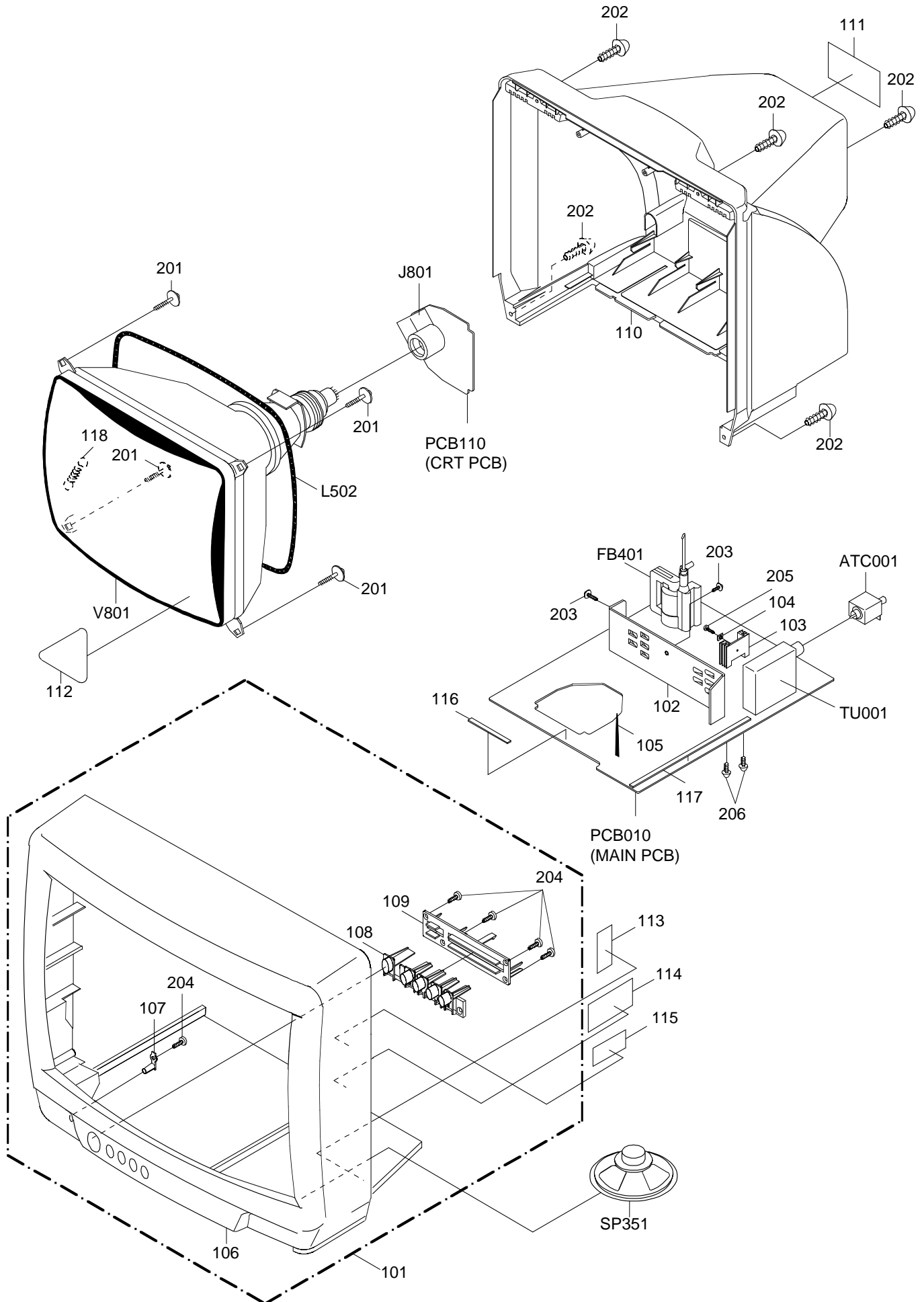

## MECHANICAL REPLACEMENT PARTS LIST

REF. NO.	PART NO.	DESCRIPTION	
101	A3H654C720	CABINET,FRONT ASS'Y	
102	---	HEAT SINK	
103	---	HEAT SINK	
104	---	METAL SPACER	
105	---	COATING CLIP	
106	701WPJA862	CABINET,FRONT	
107	713WPA0090	GUIDE,REMOCON	
108	735WPA0381	BUTTON,FRAME	
109	735WPA0382	BUTTON,HOLDER	
110	702WPA0557	CABINET,BACK	
111	722A08A059	SHEET,RATING	
112	723000A932	FILM,DECORATION	
113	7230006818	SHEET,CAUTION	
114	7220001119	SHEET,CSA WARNING	
115	7220001107	SHEET,HWC	
116	800WQ00044	FELT SHEET	5x50xT0.5
117	800WQ00045	FELT SHEET	5x150xT0.5
118	741WUA0019	SPRING,EARTH	
201	8121F50B84	SCREW,TAPPING (B0)	GW20 5x28
202	8117540A64	SCREW,TAPPING (B0)	TRUSS 4x16
203	8117D30A04	SCREW,TAPPING (B0)	WH8 BRAZIER 3x10
204	8110630A04	SCREW,TAP TITE (P)	BRAZIER 3x10
205	810A130804	SCREW/WASHER (A)	M3x8
206	8109630802	SCREW,TAP TITE (B)	BRAZIER 3x8
---	JB5K0100	POLYBAG	
---	J3H65401	INSTRUCTION BOOK	
---	791WHAA017	LAMIFILM BAG	
---	792WHA0244	PACKAGE,BOTTOM	
---	792WHA0245	PACKAGE,TOP	
---	793WCDA705	GIFT BOX	



# ELECTRICAL REPLACEMENT PARTS LIST

REF. NO.	PART NO.	DESCRIPTION	REF. NO.	PART NO.	DESCRIPTION
<b>RESISTORS</b>					
△ R177	R5W2CF122J	R, CEMENT	1.2K OHM 10W	△ D503	D2WTRM11C0 DOIDE, SILICON RM11C-EIC
△ R401	R4X5T4104F	R, METAL	100K OHM 1/4W	△ D504	D2WTRM11C0 DOIDE, SILICON RM11C-EIC
△ R404	R001T6272J	RC	2.7K OHM 1/6W	D601	D1VT001330 DIODE, SILICON 1SS133T-77
△ R405	R4X5T4183F	R, METAL	18K OHM 1/4W	D602	D97U08R21B DIODE, ZENER MTZJ8.2B T-77
△ R406	R903N8222J	RC	2.2K OHM 1/8W	D603	D1VT001330 DIODE, SILICON 1SS133T-77
△ R407	R3X1812R2J	R, METAL OXIDE	2.2 OHM 1W	D604	D1VT001330 DIODE, SILICON 1SS133T-77
△ R408	R4X5T6103F	R, METAL	10K OHM 1/6W	D605	D2WT011E10 DIODE, SILICON 11E1-EIC
△ R409	R4X5T6562F	R, METAL	5.6K OHM 1/6W	D607	D1VT001330 DIODE, SILICON 1SS133T-77
△ R416	R002T2010J	RC	1 OHM 1/2W	D608	D9201150B1 DIODE, ZENER RD15FB
△ R417	R4X5T6113F	R, METAL	11K OHM 1/6W	D609	D2WT0EM1C0 DIODE, SILICON EM1C-EIC
△ R418	R4X5T6273F	R, METAL	27K OHM 1/6W	D610	D97U01201B DIODE, ZENER MTZJ12B T-77 or
△ R422	R002T4103J	RC	10K OHM 1/4W		D94TA12B12 DIODE, ZENER HZ12B2L TD or
△ R424	R4X5T6682F	R, METAL	6.8K OHM 1/6W		D94TA12A11 DIODE, ZENER HZ12A1L TD
△ R429	R655813R3J	R, FUSE	3.3 OHM 1W	D611	D97U01201B DIODE, ZENER MTZJ12B T-77 or
△ R443	R6558A5R6J	R, FUSE	5.6 OHM 2W		D94TA12B12 DIODE, ZENER HZ12B2L TD or
	R6358A5R6J	R, FUSE	5.6 OHM 2W		D94TA12A11 DIODE, ZENER HZ12A1L TD
△ R447	R3X18A332J	R, METAL OXIDE	3.3K OHM 2W	D612	D97U01201B DIODE, ZENER MTZJ12B T-77 or
△ R448	R3X18A332J	R, METAL OXIDE	3.3K OHM 2W		D94TA12B12 DIODE, ZENER HZ12B2L TD or
△ R449	R3X18A332J	R, METAL OXIDE	3.3K OHM 2W		D94TA12A11 DIODE, ZENER HZ12A1L TD
△ R501	R21202105K	R, SOLID	1M OHM 1/2W	D613	D1VT001330 DIODE, SILICON 1SS133T-77
△ R502	R5X2CE3R9J	R, CEMENT	3.9 OHM 7W	D614	D2WT011E10 DIODE, SILICON 11E1-EIC
△ R506	R5W2CH181J	R, CEMENT	180 OHM 20W	D615	D97U06R21B DIODE, ZENER MTZJ6.2B T-77
△ R507	R655U4470J	R, FUSE	47 OHM 1/4W	<b>ICS</b>	
△ R509	R4X5T6123F	R, METAL	12K OHM 1/6W	IC101	I56F07044A IC OEC7044A
△ R515	R3X28B1R5J	R, METAL	1.5 OHM 3W	IC199	A3H651C015 IC S-24C02BDP-11
△ R629	R001T6182J	RC	1.8K OHM 1/6W	△ IC351	I03DP75110 IC AN7511
△ R640	R5W2CF152J	R, CEMENT	1.5K OHM 10W	△ IC401	I03TD80400 IC LA78040
△ R655	R5X2CF182J	R, CEMENT	1.8K OHM 10W	△ IC402	I1KA978050 IC KIA7805PI
△ R803	R3X18A123J	R, METAL OXIDE	12K OHM 2W	△ IC501	I2B4901100 IC STR30110
△ R805	R3X18A123J	R, METAL OXIDE	12K OHM 2W	△ IC601	I06FC12030 IC M61203BFP
△ R807	R3X18A123J	R, METAL OXIDE	12K OHM 2W	<b>TRANSISTORS</b>	
<b>CAPACITORS</b>					
C132	E02L03222M	CE	2200 UF 25V	Q101	TNYTJ03001 COMPOUND TRANSISTOR DTC114TSTP
△ C404	E02LT1471M	CE	470 UF 10V	△ Q401	TDUU024990 TRANSISTOR, SILICON 2SD2499(LBOEC1)
△ C405	E02LT2471M	CE	470 UF 16V	△ Q402	TC3Q026210 TRANSISTOR, SILICON 2SC2621(D,E)-RAC
△ C412	E02LT1471M	CE	470 UF 10V	Q403	TPYTD03001 COMPOUND TRANSISTOR DTA144ESTP
△ C414	E02LT4101M	CE	100 UF 35V	Q501	TC5T018154 TRANSISTOR, SILICON 2SC1815Y(TPE2)
C416	P3N1F2123J	CPP	0.012 UF 200V	Q603	TD3T007340 TRANSISTOR, SILICON 2SD734(E,F)-AA
△ C418	E02LF3102M	CE	1000 UF 25V	Q606	TD3T007340 TRANSISTOR, SILICON 2SD734(E,F)-AA
△ C433	E02LT4471M	CE	470 UF 35V	Q608	TA5T010154 TRANSISTOR, SILICON 2SA1015Y(TPE2)
△ C434	E02LT8220M	CE	22 UF 100V	△ Q801	TC3F042170 TRANSISTOR, SILICON 2SC4217(D,E)-RAC
C437	P447F2474J	CMPP	0.47 UF 200V FHS	△ Q802	TC3F042170 TRANSISTOR, SILICON 2SC4217(D,E)-RAC
△ C443	P4N8FJ562H	CMPP	0.0056UF 1.25KV	△ Q803	TC3F042170 TRANSISTOR, SILICON 2SC4217(D,E)-RAC
△ C444	C01BBP7H2K	CC	220 PF 2KV BP	<b>COILS &amp; TRANSFORMERS</b>	
△ C446	E5EZTB010M	CE	1UF 160V	L101	021LA63R3K COIL 3.3 UH
△ C448	E02LT8220M	CE	22 UF 100V	L406	02186G180M COIL 18 UH
C450	C0J0B05H3K	CC	0.0022UF 500V B	△ L501	029K000074 COIL, LINE FILTER 9-000074
	C0JTB05H3K	CC	0.0022UF 500V B	△ L502	028R200026 COIL, DEGAUSS 8R200026
△ C502	P2122B104M	CMP	0.1 UF 250V ECQUL	L601	0216731R2K COIL 1.2 UH
△ C506	E52DGC471M	CE	470 UF 200V	L603	021673100K COIL 10 UH
C507	E02YFB101M	CE	100 UF 160V	L605	0216731R0J COIL 1 UH
△ C519	E02LTB100M	CE	10UF 160V	L606	021LA62R2K COIL 2.2 UH
C624	E02LF2222M	CE	2200 UF 16V	L607	021LA6150K COIL 15 UH
C646	E02L03222M	CE	2200 UF 25V	L801	02167D221K COIL 220 UH
C653	CHGTY0214M	CC	0.01 UF 16V Y	T401	03305Y0018 TRANS, HORIZONTAL DRIVE 305Y001
C654	CHGTB04Q2K	CC	470 PF 50V B	<b>JACK</b>	
C655	CHGTB04H2J	CC	220 PF 50V B	△ J801	066X120014 SOCKET, CRT HPS3200-010501
<b>DIODES</b>					
D001	D94TA30013	DIODE, ZENER	HZ30-3L TD	SW101	0504201T31 SWITCH, TACT SKHVBED010
D101	D97U06R81B	DIODE, ZENER	MTZJ6.8B T-77	SW102	0504201T31 SWITCH, TACT SKHVBED010
D103	D97U06R81B	DIODE, ZENER	MTZJ6.8B T-77	SW103	0504201T31 SWITCH, TACT SKHVBED010
D104	D97U06R81B	DIODE, ZENER	MTZJ6.8B T-77	SW104	0504201T31 SWITCH, TACT SKHVBED010
D125	D1VT001330	DIODE, SILICON	1SS133T-77	SW105	0504201T31 SWITCH, TACT SKHVBED010
△ D126	D2WT0EM1C0	DIODE, SILICON	EM1C-EIC	<b>P.C. BOARD ASSEMBLIES</b>	
D127	D1VT001330	DIODE, SILICON	1SS133T-77	PCB010	A3H654C01A PCB ASSY TM9454A
△ D401	D94TA27011	DIODE, ZENER	HZ27-1L TD	PCB110	A3H654C11A PCB ASSY TC9313A
△ D402	D94TA11B11	DIODE, ZENER	HZ11B1L TD	<b>MISCELLANEOUS</b>	
D403	D2WT011E10	DIODE, SILICON	11E1-EIC	△ ATC001	0632400008 ANT, UNIT NXC0032-010010
△ D404	D2WTAU02A0	DIODE, SILICON	AU02A-EIC	CD351	06CH12403B CORD CONNECTOR CH12403B
△ D405	D97U06R21B	DIODE, ZENER	MTZJ6.2B T-77	△ CD501	120R614908 CORD, AC 0R614908 or
△ D407	D2WTAU02A0	DIODE, SILICON	AU02A-EIC		1207614908 CORD, AC 7614908
△ D408	D2WTAU02A0	DIODE, SILICON	AU02A-EIC	CD801	068M82025A CORD, CONNECTOR 8M82025A
△ D410	D2WTAU02A0	DIODE, SILICON	AU02A-EIC	CF601	1022T45R72 FILTER, SAW SAF45MFY220ZR
△ D411	D2WTAU02A0	DIODE, SILICON	AU02A-EIC	CF603	1011T4R504 FILTER, CERAMIC EFCT4R5YS5A
△ D422	D2WTAU02A0	DIODE, SILICON	AU02A-EIC	CF604	1011T4R517 FILTER, CERAMIC EFCT4R5MW5
△ D501	D2WTRM11C0	DOIDE, SILICON	RM11C-EIC	△ CP351	069W120019 CONNECTOR PCB SIDE TID-X02P-B2
△ D502	D2WTRM11C0	DOIDE, SILICON	RM11C-EIC	△ CP401	069X450029 CONNECTOR PCB SIDE B05B-DVS
				△ CP501	0697320039 CORD, UX CONNECTOR THL-P03P-B1

# ELECTRICAL REPLACEMENT PARTS LIST

REF. NO.	PART NO.	DESCRIPTION	
<b>MISCELLANEOUS</b>			
CP502	069W420029	CONNECTOR PCB SIDE	TV-50P-02-A1
CP601	0694260139	CONNECTOR PCB SIDE	173979-6
CP801	069W320018	CONNECTOR PCB SIDE	TS-80P-02-V1
CP806	069W010010	CONNECTOR PCB SIDE	005P-2100
CP802A	067R010019	WIRE HOLDER	51048-1000
CP802B	067R010019	WIRE HOLDER	51048-1000
CUS001	800WF00004	CUSHION-A	
△ F501	081PA04003	FUSE	233004-MB000
△ FB401	043220045F	TRANSFORMER, FLYBACK	3220045F
FH501	06710T0006	HOLDER, FUSE	EYF-52BC
FH502	06710T0006	HOLDER, FUSE	EYF-52BC
OS101	077Q014003	REMOTE, RECEIVER	PIC-28143SY-2
△ RY101	0560V20115	RELAY	ALKS321
△ SP351	070C732001	SPEAKER	C908-8-03A or
	070C132014	SPEAKER	811-08-194
TH501	DF40A3R0Q0	DEGAUSS ELEMENT	PTAD14K2-3R0Q141
TM101	076R074180	TRANSMITTER	R25-1127
△ TU001	0145S00049	TUNER UHF-VHF	ENV56D67G3
△ V801	098Y200480	COLOR PICTURE TUBE W/DY	A48LGS30X19N45
X101	1002T00801	CERAMIC OSILLATOR	8MHz
X602	100CT3R505	CRYSTAL HC-49/C	3.579545MHz

**RESISTOR**

RC..... CARBON RESISTOR

**CAPACITORS**

CC..... CERAMIC CAPACITOR  
 CE..... ALUMI ELECTROLYTIC CAPACITOR  
 CP..... POLYESTER CAPACITOR  
 CPP..... POLYPROPYLENE CAPACITOR  
 CPL..... PLASTIC CAPACITOR  
 CMP..... METAL POLYESTER CAPACITOR  
 CMPL..... METAL PLASTIC CAPACITOR  
 CMPP..... METAL POLYPROPYLENE CAPACITOR

SPEC.NO.	M3H6-54C
O/R NO.	W033021